

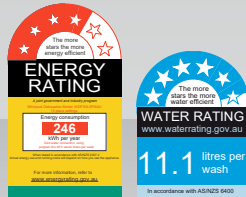

W Collection

WDFS3L5PIXAU 60CM 15 PLACE SETTING FREE-STANDING DISHWASHER



FEATURES & BENEFITS



6TH SENSE TECHNOLOGY

With 6th sense technology, it automatically senses how dirty the dishes are and adapts the cycle time and water pressure accordingly. It ensures to provide the perfect performance with water, energy & time saving.



POWER CLEAN PRO

Powerful water jets on the rear of the machine work to deliver supreme cleaning results on the toughest soil.



MAXI-SPACE

Thanks to the Maxi-Space, the dishwasher provides you with a larger internal usable space that offers you greater ease and versatility to fit all your soiled dishes within.



HALF LOAD

If there are not many dishes to be washed, a half loading may be used in order to save water, electricity and detergent.



SANITIZATION

Thanks to Sanitization option, it could eliminates 99.999% bacteria and provide more HYGIENE experience



NATURAL DRY

The automatic door opening at the end of the program ensures better and more natural drying. This system guarantees higher energy efficiency and better drying results.



FLEXIBLE UPPER RACK

The height of the upper rack can be adjusted according to your needs: high position to place bulky crockery in the lower basket and low position to make the most of the tip-up supports by creating more space upwards and avoid collision.

TECHNICAL SPECIFICATIONS

| | |
|-------------------------|---|
| COLOUR / FINISH | Stainless Steel Color |
| DISPLAY | LED Display |
| CONTROL | Touch UI |
| DOOR / HANDLE DESIGN | Square |
| CAPACITY | 15 place settings |
| NET WEIGHT | 50kg |
| PRODUCT DIMENSION | W 600mm x H 850mm x D 590mm |
| PROGRAMMES | Eco, Auto Intensive, Auto Mixed, Auto Fast, Crystals, Rapid, Prewash, Selfclean |
| FEATURES | 6th Sense, Power Clean, Modular cutlery rack, Half Load, Sanitization, Natural Dry, Removable upper rack with double cup shelves and rubber mat for glass protection, Removable Lower rack with Pan holder, Dual Inverter, 15 Place Setting, Maxi-Space |
| NOISE | 41 dBA |
| WATER CONSUMPTION | 11.1 liters |
| WATER RATING | 5.5 stars rating |
| ENERGY CONSUMPTION | 246 kwh/year |
| ENERGY RATING | 4.0 stars rating |
| VOLTAGE | 220 - 240V |
| CURRENT | 10 amp |
| PLUG TYPE | Australian |
| LENGTH OF HOSE | Inlet: 155cm Outlet: 150 cm |
| LENGTH OF ELECTRIC CORD | 130cm |
| PACKAGING DIMENSIONS | W 625mm x H 910mm x D 675mm |
| GROSS WEIGHT | 53kg |
| WARRANTY | 5 Years |
| PLACE OF MANUFACTURE | Made in China |

DISTRIBUTED BY ARISIT PTY LTD

40-50 Mark Anthony Drive, Dandenong South VIC 3175
Ph: 1300 762 219 Fax: 03 9768 0838 Website: www.arisit.com

INSTALLATION GUIDE

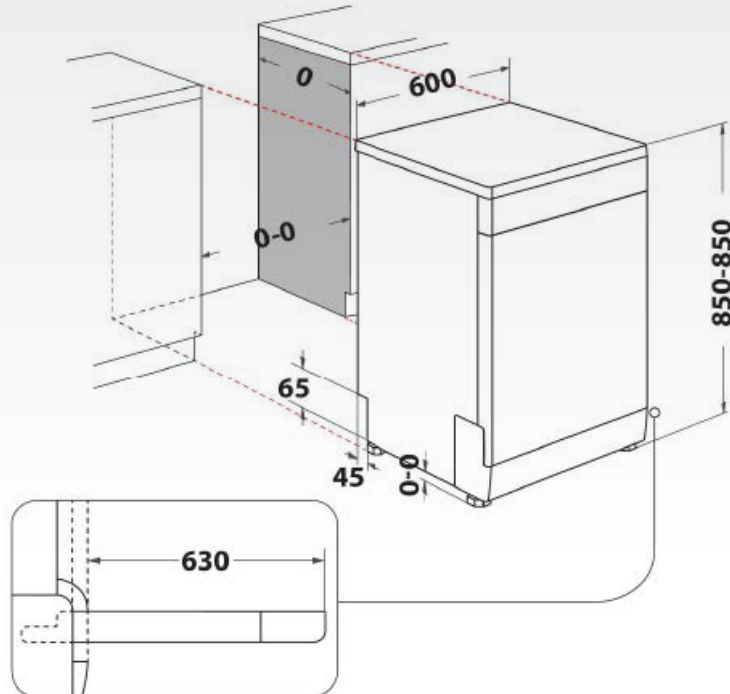

CONTROL PANEL

CONTROL PANEL



- | | |
|---|--|
| <ol style="list-style-type: none"> 1. ON-OFF/Reset button with indicator light 2. Eco program button with indicator light 3. Auto Intensive program button with indicator light 4. Auto Mixed program button with indicator light 5. Auto Fast program button with indicator light 6. Rapid program button with indicator light 7. Crystals program button with indicator light 8. Prewash program button with indicator light 9. Salt reservoir empty indicator light 10. Rinse Aid reservoir empty indicator light 11. Display | <ol style="list-style-type: none"> 12. Program number and remaining time indicator 13. Closed water tap indicator light 14. DESCALE indicator light 15. Power Clean® option button with indicator light 16. Half Load option button with indicator light/ Settings - 3 sec. press 17. Extra Dry option button with indicator light 18. Silent option button with indicator light/ Key lock - 3 sec. press 19. Sani Rinse option button with indicator light 20. Self-Clean program button with indicator light 21. Delay option button with indicator light 22. START/Pause button with indicator light |
|---|--|